

Roof-Top Power Ventilators & Fresh Air Intakes For Commercial, Industrial and Agricultural Requirements

Features:

- Factory tested and shipped ready to operate, including factory wired components
- ETL listed and labeled in accordance with U.L. standards
- Copper-wound heavy duty ball bearing motors
- Self-aligning, heavy duty, greaseable, pillow block, ball type fan bearing
- Aluminum Construction with Key Steel Components
- Adjustable motor sheave for air flow adjustment
- Lifting sky hooks
- The most up-to-date propeller type axial fan affords maximum air delivery while minimizing horsepower
- Interchangeable components with UMP-700 Series evaporative coolers
- Tilting hinged access hood for ease of maintenance
- 1/4" by 1/4" Birdscreen

• UE Series

• Exhaust / Intake

- UE 30
- UE 36
- UE 42
- UE 48
- UE 48-2

Available Options

- Pre-wired control packages
- Spark resistant fans
- Explosion proof motors
- Self-tensioning belt
- Installation accessories
- Back draft damper
- Safety guards
- Fused and non-fused disconnects

Resources Available for this Product

- Catalog By Mail
- Catalog Online



United Metal Products

1920 E Encanto Drive Tempe, AZ 85281

T 480.968.9550

F 480.968.9555

www.unitedmetal.com

Model #	AIR DELIVERY IN CUBIC FEET PER MINUTE								ELECTRICAL SPECIFICATIONS				FAN UNIT					Dimensions (Inches)						Weights ²	
	Inches Static Pressure (W.G.)								Fan Motor ¹				Fan		Drives			A	B	C	D	E	F		
	FREE AIR CFM	RPM	0.125 CFM	RPM	0.25 CFM	RPM	0.375 CFM	RPM	HP	Max BHP	Volt/Phase 115/208/230 1 Phase Amps	Volt/Phase 208/230/460 3 Phase Amps	Dia.	Max RPM	Motor Pulley O.D.	Fan Pulley O.D.	Belt								Shaft
UE30 Exhaust (E) Intake (I)	9,330	676	8,080	676	3,570	676	--	--	1/2	.57	7.2 / 4.1 / 3.6	2.4 / 2.0 / 1.0	30"	800	3.15	7.95	A40	1"	33.75	33.75	60	68	18.00	32.5	249
	10,650	771	9,610	771	7,710	771	5,150	771	3/4	.86	10.6 / 6.0 / 5.3	3.6 / 3.0 / 1.5	30"	800	3.75	7.95	A40	1"	33.75	33.75	60	68	18.00	32.5	257
	11,720	849	10,800	849	9,490	849	6,960	849	1	1.15	13.0 / 6.3 / 6.5	3.9 / 4.0 / 2.0	30"	800	3.75	6.95	A40	1"	33.75	33.75	60	68	18.00	32.5	259
UE36 Exhaust (E) Intake (I)	12,500	550	10,870	550	7,360	550	--	--	3/4	.86	10.6 / 6.0 / 5.3	3.0 / 3.4 / 1.7	36"	800	3.75	11.25	A44	1"	39.75	39.75	78	80	18.00	32.5	299
	13,830	610	12,330	610	9,980	610	--	--	1	1.15	13.0 / 6.3 / 6.5	3.6 / 3.8 / 1.9	36"	800	4.15	11.25	A44	1"	39.75	39.75	78	80	18.00	32.5	300
	15,610	680	14,300	680	12,770	680	9,350	680	1 1/2	1.73	18.0 / 9.5 / 9.0	4.5 / 4.2 / 2.1	36"	800	4.75	11.25	A44	1"	39.75	39.75	78	80	18.00	32.5	312
UE42 Exhaust (E) Intake (I)	16,890	470	14,610	470	9,840	470	--	--	1	1.15	13.0 / 6.3 / 6.5	3.6 / 3.8 / 1.9	42"	690	3.15	11.25	A48	1"	45.75	45.75	90	80	18.00	32.5	339
	19,070	530	17,100	530	14,260	530	--	--	1 1/2	1.73	18.0 / 9.5 / 9.0	4.5 / 4.2 / 2.1	42"	690	3.75	11.25	A48	1"	45.75	45.75	90	80	18.00	32.5	351
	20,970	580	19,190	580	17,100	580	12,460	580	2	2.3	24.0 / 12.6 / 12.0	5.9 / 5.6 / 2.8	42"	690	4.15	11.25	A48	1"	45.75	45.75	90	80	18.00	32.5	371
UE48 Exhaust (E) Intake (I)	22,710	430	19,850	430	13,880	430	--	--	1 1/2	1.73	18.0 / 9.5 / 9.0	4.5 / 4.2 / 2.1	48"	630	3.75	14.25	A60	1"	53.75	53.75	98	92	18.00	32.5	400
	25,050	470	22,500	470	18,940	470	--	--	2	2.3	24.0 / 12.6 / 12.0	5.9 / 5.6 / 2.8	48"	630	4.15	14.25	A60	1"	53.75	53.75	98	92	18.00	32.5	420
	28,620	540	26,410	540	23,930	540	18,630	540	3	3.45	32.0 / 16.8 / 16.0	8.7 / 8.0 / 4.0	48"	630	4.75	14.25	A60	1"	53.75	53.75	98	92	18.00	32.5	432
UE48-2 Exhaust (E) Intake (I)	45,420	430	39,700	430	27,760	430	--	--	(2) 1 1/2	(2) 1.73	(2) - 18.0 / 9.5 / 9.0	(2) - 4.5 / 4.2 / 2.1	(2) 48"	630	3.75	14.25	A60	1"	53.75	107.75	98	148	18.00	32.5	668
	50,100	470	45,000	470	37,880	470	--	--	(2) 2	(2) 2.3	(2) - 24.0 / 12.6 / 12.0	(2) - 5.9 / 5.6 / 2.8	(2) 48"	630	4.15	14.25	A60	1"	53.75	107.75	98	148	18.00	32.5	708
	57,240	540	52,820	540	47,860	540	37,260	540	(2) 3	(2) 3.45	(2) - 32.0 / 16.8 / 16.0	(2) - 8.7 / 8.0 / 4.0	(2) 48"	630	4.75	14.25	A60	1"	53.75	107.75	98	148	18.00	32.5	732

* Performance ratings shown does not include drive losses or system effect. Consider a minimum of 0.125" pressure on all systems.
 * Performance shown is for installation Type A: Free Inlet, Free Outlet.
 * Power rating (BHP) does not include drive losses.

- 1 Only motors 1hp or less are provided with integral thermal protection. Motors 1.5 hp or greater require a separate motor overload device. Amperage ratings shown is nameplate data. Consult factory for overload and control options.
- 2 Weights are in pounds and include motors, belts, and drives. Weights exclude optional accessories such as curb, damper and controls.
- 3 Electrical Connects are centered on the motor side by default.

CAUTION: Do not use in hazardous environments where the fan's electrical system could provide ignition to combustible or flammable materials, unless unit is specifically built for hazardous environments.

WARNING: Guards must be installed when fan is within reach of personnel or within seven (7) feet of working level or when deemed advisable for safety.

End View

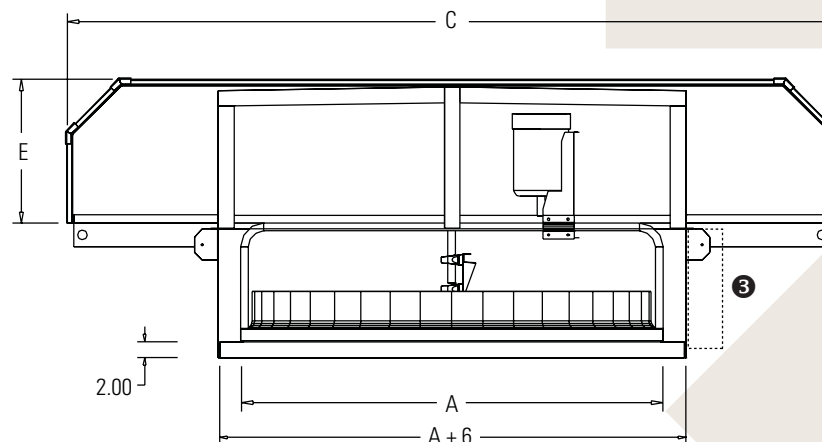

Side View

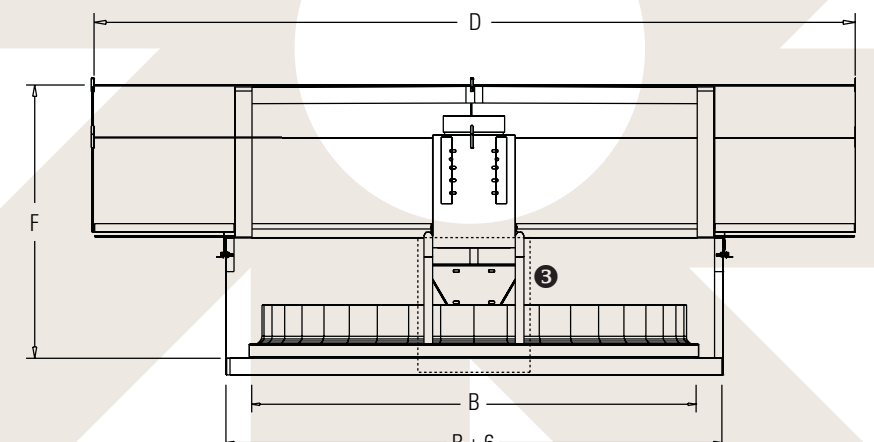



UE Optional Accessories

Description	Part #	A	B	Weight in lbs.
UE30 Roof Curb	81225	34.25"	34.25"	45
UE36 Roof Curb	65651	40.25"	40.25"	55
UE42 Roof Curb	65652	46.25"	46.25"	65
UE48 Roof Curb	65653	54.25"	54.25"	75
UE48-2 Roof Curb	65654	54.25"	108.25"	110

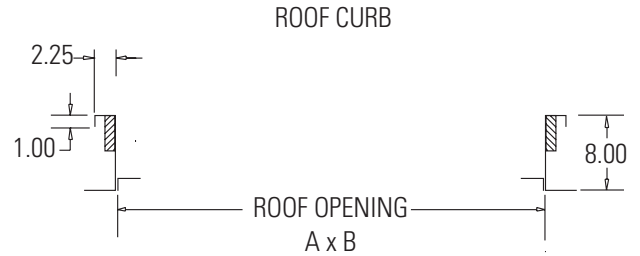

Description	Part #	A	B	Weight in lbs.
UE30 Gravity Damper	73037	34.00"	34.00"	23
UE36 Gravity Damper	65750	40.00"	40.00"	27
UE42 Gravity Damper	65751	46.00"	46.00"	29
UE48 Gravity Damper	65752	54.00"	54.00"	37
UE48-2 Gravity Damper	65753	54.00"	108.00"	73

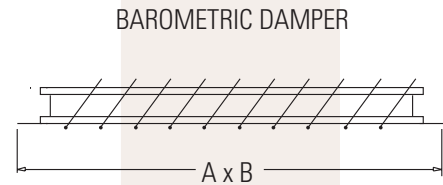

Description	Part #	A	B	Weight in lbs.
UE30 Safety Grill	70666	33.00"	33.00"	9
UE36 Safety Grill	52115	39.00"	39.00"	11
UE42 Safety Grill	52116	45.00"	45.00"	14
UE48 Safety Grill	52117	51.00"	51.00"	18
(2) UE48-2 Safety Grill	(2) 52117	51.00"	51.00"	(2) 18

